



ExcaDrill

Fiches Techniques



MiniDrill BBD 94

Drilling Attachment

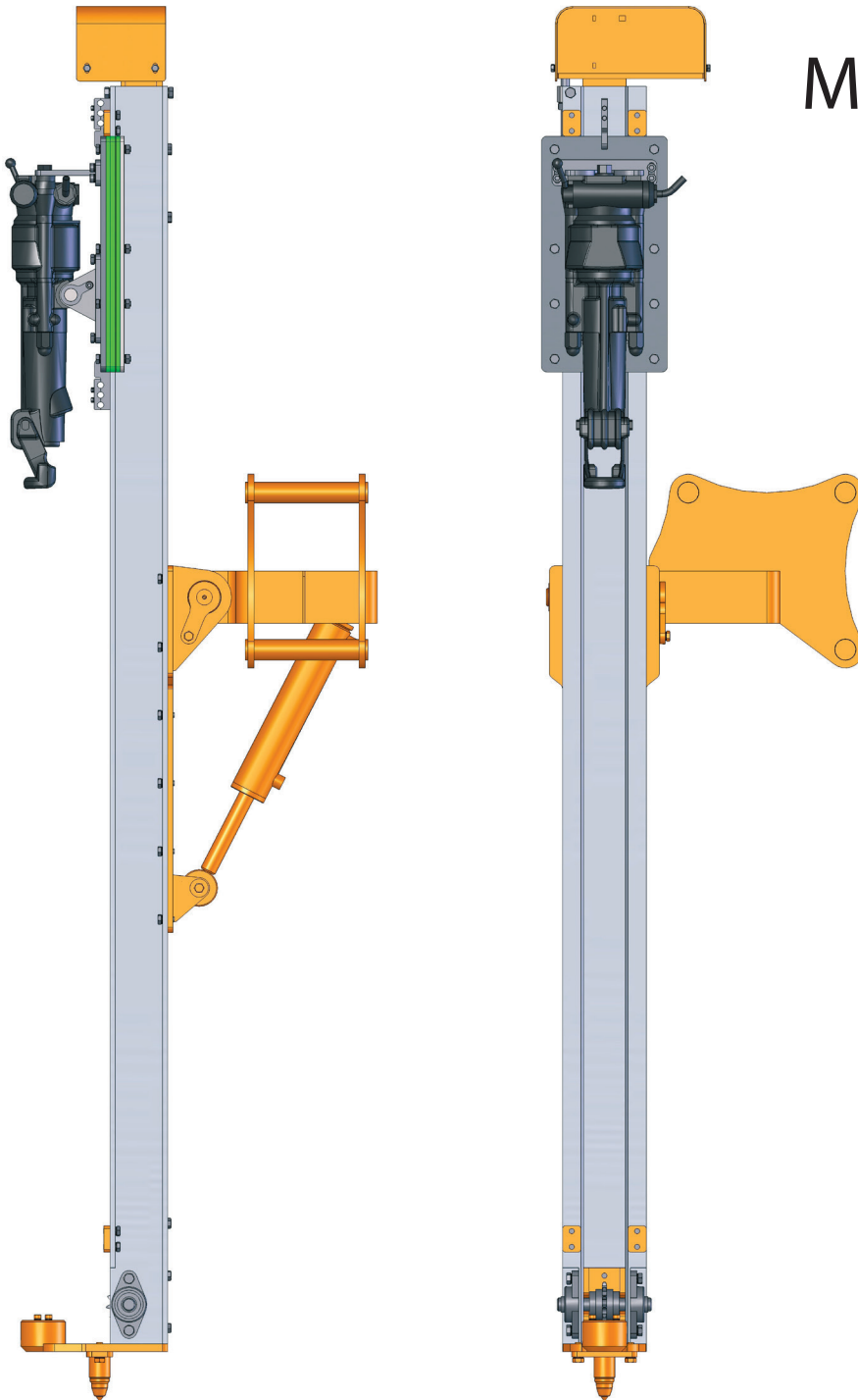

Drilling attachment

Type		MiniDrill		
Length	Total length	mm (ft)	2670	(8,8)
	Transportation length	mm (ft)	1600	(5,2)
Width		mm (ft)	681	(2,2)
Height		mm (ft)	615	(2)
Weight		kg (lb)	200	(440)
Max. FeedForce	at 175 bar (2538 psi)	kN (lbf)	3,75	(843)
Max. FeedSpeed	at 25 LPM (6,6 gpm)	m/s ft/s	1,3	(4,3)
Cross Tilting		°	+/-20	

Drifter

Type		Atlas Copco BBD 94		
Air consumption at 6 bar (87 psi)		l/s (gps)	97	(26)
	Piston diameter	mm (in)	90	(3,54)
Stroke length		mm (in)	45	(1,77)
Impact rate at 6 bar (87 psi)		Hz	55	
Overall length		mm (ft)	653	(2,1)
Weight		kg (lb)	26	(57)
Hole diameters		mm (in)	27-41	(1 1/16 - 1 5/8)
Chuck, hex shank std		mm (in)	22 X 108	(7/8 X 4 1/4)

Noise & Vibration Declaration Statement

Sound pressure level	db (A)	119
in accordance with ISO 11201		

Vibration Declaration Statement

Vibration level	s2	23
in accordance with ISO 8662		

Optional equipment

Mounting Kit for excavator

22A

Drilling Attachment

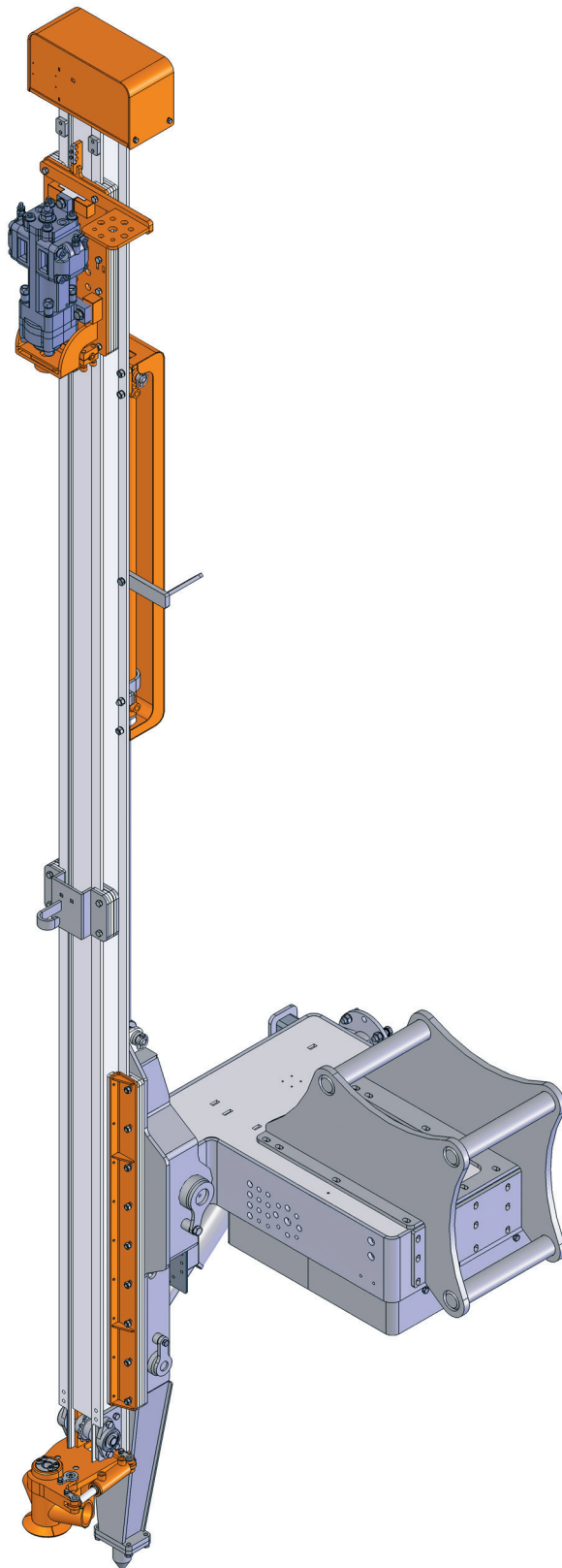

Drifter

Manufacturer	Doofer	
Type	DF430X	
Impact power	kW	5,0
Max input power to rock drill	kW	9,3
Impact energy	J	60
Hydraulic pressure, max	bar	130
Torque, max	Nm	100
Impact frequency	Hz	100-115

Dimensions and weights

Weight	kg	920 (w/o coupling)
Length	mm	5050
Width	mm	1200
Height	mm	1100 (w/o coupling)

Drill Steel

Hole range	mm	30 - 41
Drill steel	7/8" - 1" / R25	

Dust collector

Model	ECON600	
Filter area	m ²	4,8
Number of filter elements	pcs	6
Suction capacity (max. nominal)	l/s	275
Suction hose diam	mm	76
Cleaning air pressure, max	bar	7
Cleaning air consumption	l/pulse	20

Compressor

Type	Rotary vane	
Model	HKL1300	
Capacity	lpm	1300
Working pressure	bar	7

Feed system

Feed extension	mm	1000
Feed force, max	kN	9,2
Tractive pull, max	kN	9,2
Total length	mm	5050

AutoDrill drilling automatic system

Pressure adjustments during drilling	standard
X / Y angles with lights and numbers	standard
Penetration rate	standard
Hole depth	standard
Stop depth form surface	standard
Stop depth from laser level	option
Reading of hydraulic oil temperature	standard

Accessories

Boom camera	option
Laser receiver	option
Central lubrication system	option
Extra mounting kit for additional excavator	option
GPS system	option

Hydraulic system

Controls	AutoDrill automatic drilling with CAN-control from excavator cabin
Anti-jamming	Anti-jamming integrated in AutoDrill automatic drilling in all models
Oil cooling	Cooler for compressor motor return flow is available

Carrier requirements

Weight	tn	9 - 21
Flow / pressure for drilling	LPM @ Bar	85 @ 150
Flow / pressure for compressor	LPM @ Bar	40 @ 150
Flow / pressure for dust collector	LPM @ Bar	25 @ 150
Total flow / pressure; min	LPM @ Bar	130 @ 150
Total flow / pressure; max	LPM @ Bar	150 @ 150
Power requirement for engine	kW (min/max)	42 / 47

25A
Drilling Attachment

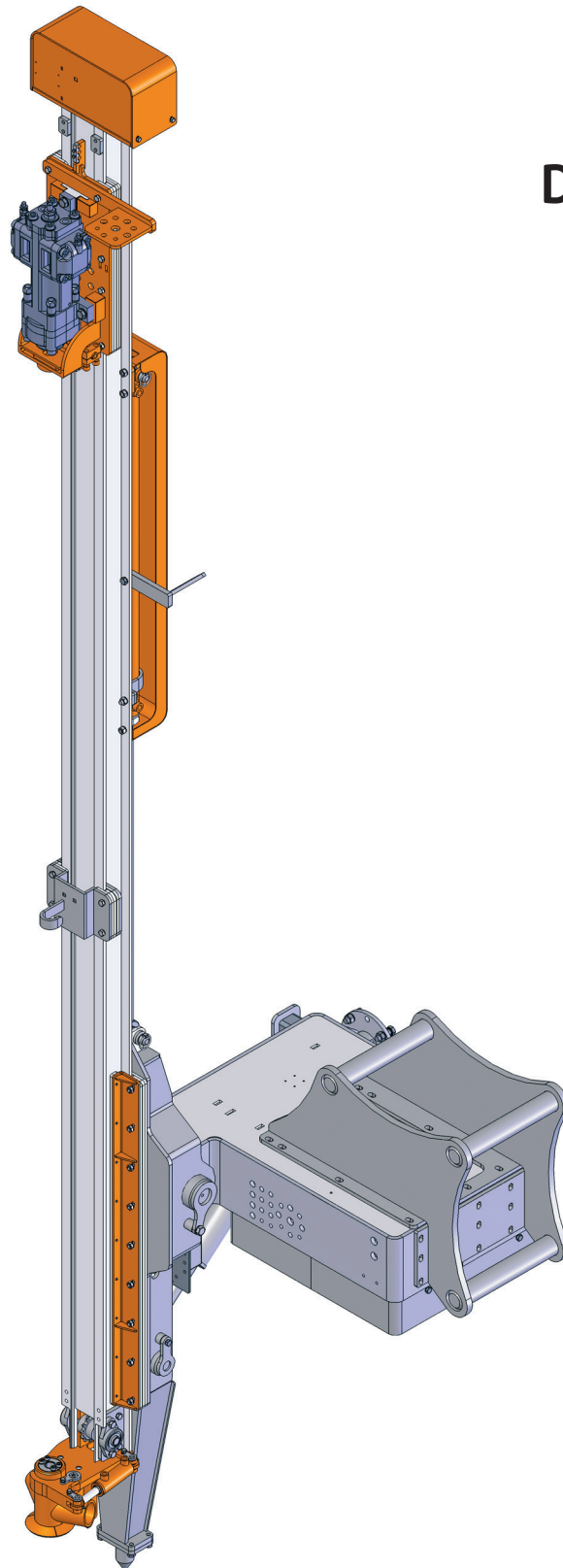

Drifter

Manufacturer		Doofer
Type		DF500X
Impact power	kW	10,0
Max input power to rock drill	kW	17
Impact energy	J	105
Hydraulic pressure, max	bar	130
Torque, max	Nm	110
Impact frequency	Hz	75-95

Dimensions and weights

Weight	kg	920 (w/o coupling)
Length	mm	5050
Width	mm	1200
Height	mm	5000 (w/o coupling)

Drill Steel

Hole range	mm	30 - 45
Drill steel		7/8" - 1" / R25

Dust collector

Model		ECON600
Filter area	m ²	4,8
Number of filter elements	pcs	6
Suction capacity (max. nominal)	l/s	275
Suction hose diam	mm	76
Cleaning air pressure, max	bar	7
Cleaning air consumption	l/pulse	20

Compressor

Type		Rotary vane
Model		HKL1300
Capacity	lpm	1300
Working pressure	bar	7

Feed system

Feed extension	mm	1000
Feed force, max	kN	9,2
Tractive pull, max	kN	9,2
Total length	mm	5050

AutoDrill drilling automatic system

Pressure adjustments during drilling	standard
X / Y angles with lights and numbers	standard
Penetration rate	standard
Hole depth	standard
Stop depth form surface	standard
Stop depth from laser level	option
Reading of hydraulic oil temperature	standard

Accessories

Boom camera	option
Laser receiver	option
Central lubrication system	option
Extra mounting kit for additional excavator	option
GPS system	option

Hydraulic system

Controls	AutoDrill automatic drilling with CAN-control from excavator cabin
Anti-jamming	Anti-jamming integrated in AutoDrill automatic drilling in all models
Oil cooling	Cooler for compressor motor return flow is available

Carrier requirements

Weight	tn	10 - 21
Flow / pressure for drilling	LPM @ Bar	90 @ 150
Flow / pressure for compressor	LPM @ Bar	40 @ 150
Flow / pressure for dust collector	LPM @ Bar	25 @ 150
Total flow / pressure; min	LPM @ Bar	140 @ 150
Total flow / pressure; max	LPM @ Bar	170 @ 160
Power requirement for engine	kW (min/max)	45 / 60

28A

Drilling Attachment

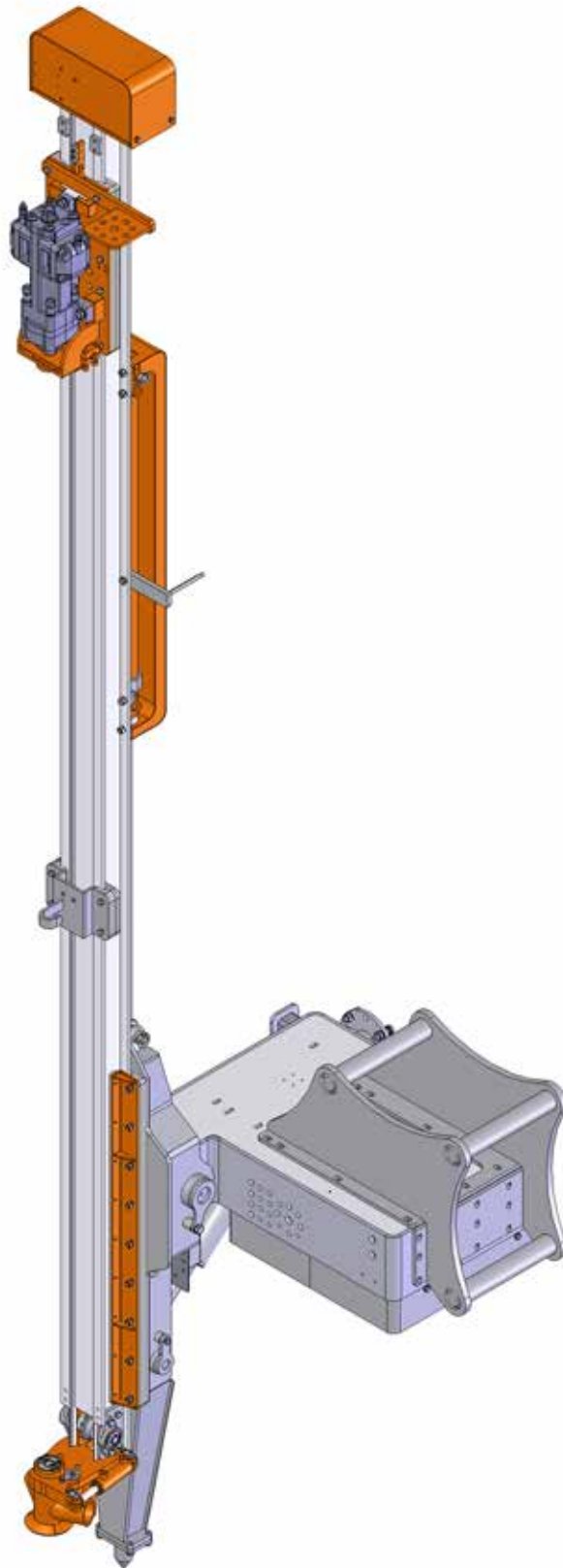

Drifter

Manufacturer		Doofer
Type		DF500S/ 538L
Impact power	kW	10/ 13
Max input power to rock drill	kW	17/ 22
Impact energy	J	105/ 135
Hydraulic pressure, max	bar	130
Torque, max	Nm	110/ 220
Impact frequency	Hz	75-95

Dimensions and weights

Weight	kg	920 (w/o coupling)
Length	mm	5700
Width	mm	1200
Height	mm	1100 (w/o coupling)

Drill Steel

Hole range	mm	38 - 51
Drill steel		R25/R28/R32/ T38

Dust collector

Model		ECON600
Filter area	m ²	4,8
Number of filter elements	pcs	6
Suction capacity (max. nominal)	l/s	275
Suction hose diam	mm	76
Cleaning air pressure, max	bar	7
Cleaning air consumption	l/pulse	20

Compressor

Type		Rotary vane
Model		HKL2600
Capacity	lpm	2600
Working pressure	bar	7

Feed system

Feed extension	mm	1000
Feed force, max	kN	12,5
Tractive pull, max	kN	12,5
Total length	mm	5700
Travel length	mm	4270

AutoDrill drilling automatic system

Pressure adjustments during drilling	standard
X / Y angles with lights and numbers	standard
Penetration rate	standard
Hole depth	standard
Stop depth form surface	standard
Stop depth from laser level	option
Reading of hydraulic oil temperature	standard

Accessories

Boom camera	option
Laser receiver	option
Central lubrication system	option
Extra mounting kit for additional excavator	option
GPS system	option

Hydraulic system

Controls	AutoDrill automatic drilling with CAN-control from excavator cabin
Anti-jamming	Anti-jamming integrated in AutoDrill automatic drilling in all models
Oil cooling	Cooler for compressor motor return flow is available

Carrier requirements

Weight	tn	13 - 21
Flow / pressure for drilling	LPM @ Bar	90 / 110 @ 150
Flow / pressure for compressor	LPM @ Bar	92 @ 170
Flow / pressure for dust collector	LPM @ Bar	25 @ 150
Total flow / pressure; min	LPM @ Bar	180/ 200 @ 150
Total flow / pressure; max	LPM @ Bar	210/ 230 @ 170
Power requirement for engine	kW (min/max)	57 / 77

38A
Drilling Attachment

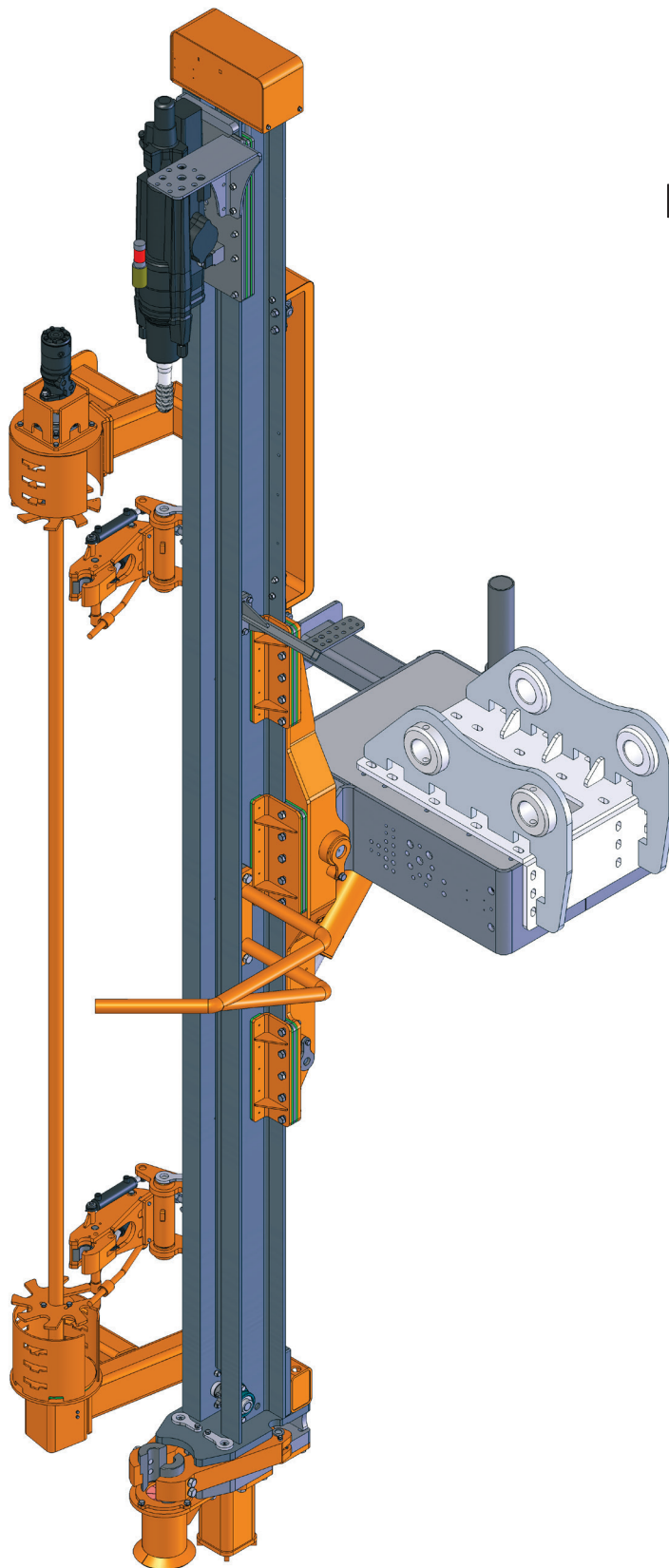

Drifter

Manufacturer	Doofor	
Type	DF550S	
Impact power	kW	17
Max input power to rock drill	kW	32
Impact energy	J	210
Hydraulic pressure, max	bar	160
Torque, max	Nm	1018
Impact frequency	Hz	55 - 68

Dimensions and weights

Weight	kg	2500 (w/o coupling)
Length	mm	6200
Width	mm	2500 + 200
Height	mm	1600 (w/o coupling)

Drill Steel

Hole range	mm	45 – 76
Drill steel	R32/T38/T45	

Dust collector

Model	HSL900	
Filter area	m ²	14,4
Number of filter elements	pcs	12
Suction capacity (max. nominal)	l/s	800
Suction hose diam	mm	127
Cleaning air pressure, max	bar	7
Cleaning air consumption	l/pulse	20

Compressor

Type	Screw	
Model	PTR50	
Capacity	lpm	5000
Working pressure	bar	7

Feed system

Feed extension	mm	1000
Feed force, max	kN	19
Tractive pull, max	kN	19
Total length	mm	6100
Travel length	mm	4270

AutoDrill drilling automatic system

Pressure adjustments during drilling	standard
X / Y angles with lights and numbers	standard
Penetration rate	standard
Hole depth	standard
Stop depth form surface	standard
Stop depth from laser level	option
Reading of hydraulic oil temperature	standard

Accessories

Boom camera	option
Laser receiver	option
Central lubrication system	option
Extra mounting kit for additional excavator	option
GPS system	option

Hydraulic system

Controls	AutoDrill automatic drilling with CAN-control from excavator cabin
Anti-jamming	Anti-jamming integrated in AutoDrill automatic drilling in all models
Oil cooling	Cooler for compressor motor return flow is available

Carrier requirements

Weight	tn	21 - 35
Flow / pressure for drilling	LPM @ Bar	210 @ 150
Flow / pressure for compressor	LPM @ Bar	135 @ 150
Flow / pressure for dust collector	LPM @ Bar	50 @ 150
Total flow / pressure; min	LPM @ Bar	270 @ 150
Total flow / pressure; max	LPM @ Bar	395 @ 150
Power requirement for engine	kW (min/max)	85 /130

45A
Drilling Attachment

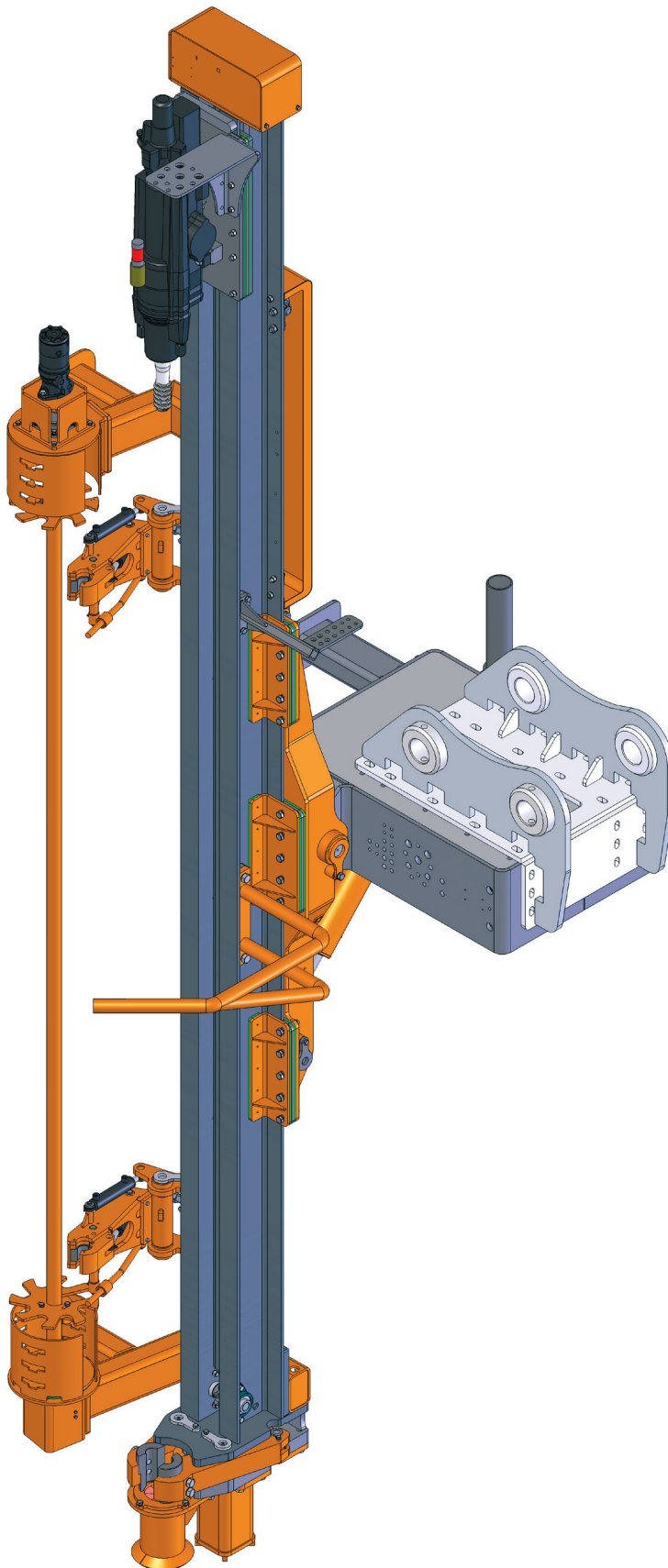

Drifter

Manufacturer	Doofor	
Type	DF560S	
Impact power	kW	20
Max input power to rock drill	kW	33
Impact energy	J	260
Hydraulic pressure, max	bar	170
Torque, max	Nm	1170
Impact frequency	Hz	55 - 67

Dimensions and weights

Weight	kg	2600 (w/o coupling)
Length	mm	6200
Width	mm	2500 + 200
Height	mm	1600 (w/o coupling)

Drill Steel

Hole range	mm	51 – 89
Drill steel	R32/T38/T45	

Dust collector

Model	HSL900	
Filter area	m ²	14,4
Number of filter elements	pcs	12
Suction capacity (max. nominal)	l/s	800
Suction hose diam	mm	127
Cleaning air pressure, max	bar	7
Cleaning air consumption	l/pulse	40

Compressor

Type	Screw	
Model	PTR60	
Capacity	lpm	6000
Working pressure	bar	7

Feed system

Feed extension	mm	1000
Feed force, max	kN	19
Tractive pull, max	kN	19
Total length	mm	6100
Travel length	mm	4270

AutoDrill drilling automatic system

Pressure adjustments during drilling	standard
X / Y angles with lights and numbers	standard
Penetration rate	standard
Hole depth	standard
Stop depth form surface	standard
Stop depth from laser level	option
Reading of hydraulic oil temperature	standard

Accessories

Boom camera	option
Laser receiver	option
Central lubrication system	option
Extra mounting kit for additional excavator	option
GPS system	option

Hydraulic system

Controls	AutoDrill automatic drilling with CAN-control from excavator cabin
Anti-jamming	Anti-jamming integrated in AutoDrill automatic drilling in all models
Oil cooling	Cooler for compressor motor return flow is available

Carrier requirements

Weight	tn	24 - 40
Flow / pressure for drilling	LPM @ Bar	230 @ 150
Flow / pressure for compressor	LPM @ Bar	145 @ 150
Flow / pressure for dust collector	LPM @ Bar	50 @ 150
Total flow / pressure; min	LPM @ Bar	290 @ 150
Total flow / pressure; max	LPM @ Bar	425 @ 150
Power requirement for engine	kW (min/max)	95 /135

51A
Drilling Attachment

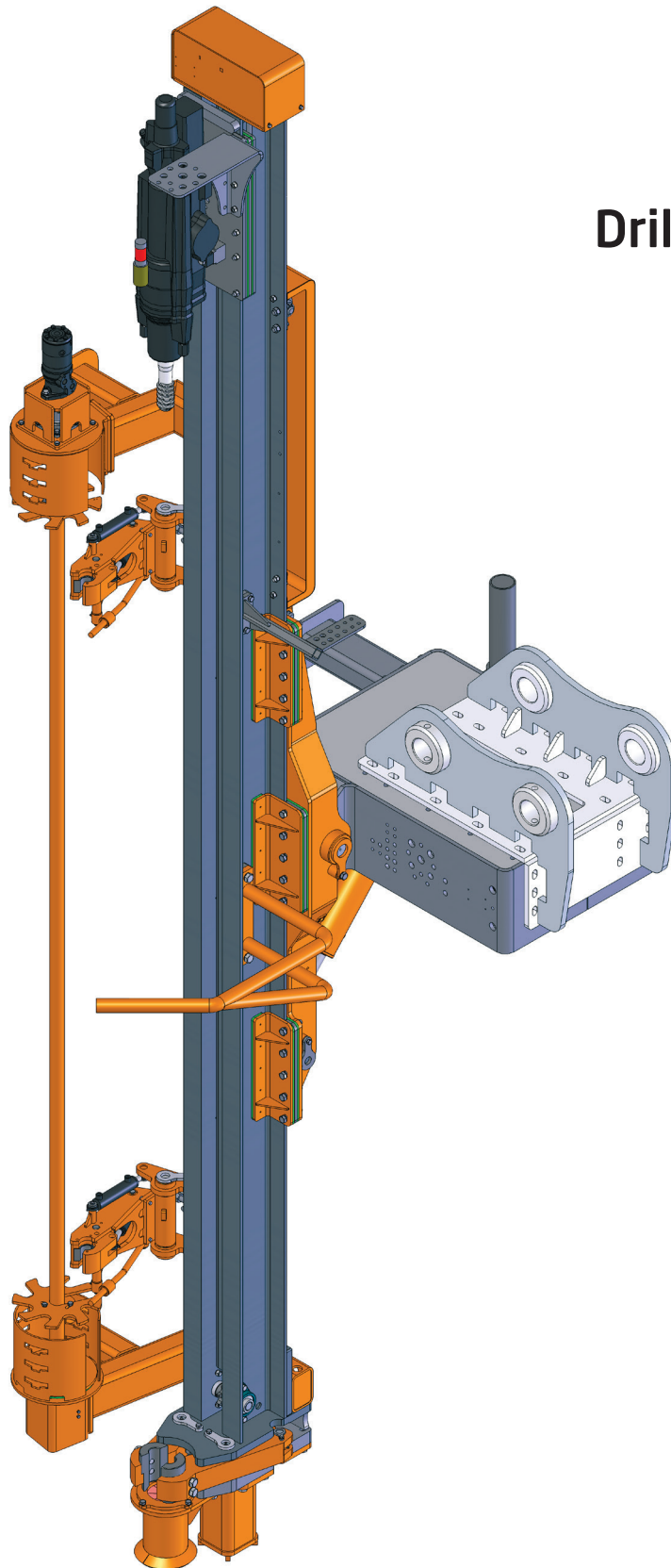

Drifter

Manufacturer	Doofer	
Type	DF800	
Impact power	kW	25
Max input power to rock drill	kW	36
Impact energy	J	470
Hydraulic pressure, max	bar	170
Torque, max	Nm	1288 (1803 opt)
Impact frequency	Hz	48 - 54

Dimensions and weights

Weight	kg	2700 (w/o coupling)
Length	mm	6200
Width	mm	2500 + 200
Height	mm	1600 (w/o coupling)

Drill Steel

Hole range	mm	64 - 127
Drill steel	T38/T45/T51	

Dust collector

Model	X-125	
Filter area	m ²	8
Number of filter elements	pcs	2
Suction capacity (max. nominal)	l/s	800
Suction hose diam	mm	127
Cleaning air pressure, max	bar	7
Cleaning air consumption	l/pulse	20

Compressor

Type	Screw	
Model	PTR75	
Capacity	lpm	7500
Working pressure	bar	7

Feed system

Feed extension	mm	1000
Feed force, max	kN	19
Tractive pull, max	kN	19
Total length	mm	6100
Travel length	mm	4270

AutoDrill drilling automatic system

Pressure adjustments during drilling	standard
X / Y angles with lights and numbers	standard
Penetration rate	standard
Hole depth	standard
Stop depth form surface	standard
Stop depth from laser level	option
Reading of hydraulic oil temperature	standard

Accessories

Boom camera	option
Laser receiver	option
Central lubrication system	option
Extra mounting kit for additional excavator	option
GPS system	option
Rod magazine for 7 rods	option

Hydraulic system

Controls	AutoDrill automatic drilling with CAN-control from excavator cabin
Anti-jamming	Anti-jamming integrated in AutoDrill automatic drilling in all models
Oil cooling	Additional oil-cooler is available

Carrier requirements

Weight	tn	32 - 45
Flow / pressure for drilling	LPM @ Bar	230 @ 150
Flow / pressure for compressor	LPM @ Bar	200 @ 150
Flow / pressure for dust collector	LPM @ Bar	44 @ 140
Total flow / pressure; min	LPM @ Bar	340 @ 150
Total flow / pressure; max	LPM @ Bar	475 @ 150
Power requirement for engine	kW (min/max)	110 /150



Forage



Minage



Attaque au sol et matériel d'usure



Nettoyeurs industriels



Produits spécifiques



MCEP DISTRIBUTION – 3 rue du Prélot
25340 L'HOPITAL SAINT-LIEFFROY



www.mcep-distribution.com



Commercial :	commercial@mcep-distribution.com	+33 7 71 24 21 58
Technique :	eric.petit@mcep-distribution.com	+33 6 26 49 69 20
Administratif :	admin@mcep-distribution.com	+33 6 48 00 66 08

